

Conval INC.

Clampseal® Valve Packing System

- Single-piece Gland
- Narrow Packing Rings
- Integral Gland Wrench
- Pressure Seal Backseat
- Cartridge Type Packing Chamber
- Thermal Isolation



The Conval Clampseal® Packing System is designed to maximize packing life in the world's most demanding high-pressure, high-temperature applications.



DESIGN FEATURES

Uniform Single-piece Gland

Proven, corrosion-inhibited, high-density graphite packing is loaded uniformly with a one-piece gland. This eliminates the potential for stem damage from gland cocking.

Surface Finishes and Close Tolerances

The stuffing box and stem are burnished stainless steel to ensure a tight seal between the system fluids and sealing surfaces. The stem and chamber provide optimal sealing surfaces and minimize wear.

Narrow Packing Rings

Narrow packing rings reduce the effect of packing shrinkage, thereby reducing the

frequency of gland adjustment. Since force = pressure x area ($F = P \times A$), by keeping the packing area to a minimum, there is less force being exerted by the system fluid, making it easier to contain.

Integral Gland Wrench

Standard on all Clampseal globe and gate valves, the Integral Gland Wrench (IGW) provides immediate gland/packing adjustment capability.

Pressure Seal Backseat

The pressure seal backseat provides maximum valve integrity by ensuring a positive internal stop for the valve step and disc assembly, and securely isolates packing from line pressure when valve is fully open, to increase packing life.

STANDARD MATERIALS

- Graphite: effective from -325F to 1200F

Lattice Braided Carbon and Die-Formed Rings

Yarn Density: 1.40 - 1.45 g/cc

Leachable Chloride: 100 ppm (max)

Total Sulfur: 770 ppm (max)

Total Chlorine: 500 ppm (max)

Total Fluorine: 300 ppm (max)

Rings are treated with a passive corrosion inhibitor

Recommended for superior sealing capability and wear resistance.

Set consists of two double-height, die-formed graphite central rings with braided end rings to prevent extrusion.

- Teflon® or reinforced Teflon® from -120F to 500F

Recommended for gas service. Molded mercury-free cup and cone arrangement produces tight sealing with minimal gland pressure.

OPTIONS

- Other packing options are available

- Live loaded gland maintains packing load for long periods of time or high cycles without routine maintenance adjustments. All Clampseal valves are available with live loaded glands, and installed valves can be retrofitted.

Cartridge Type Packing Chamber

With secure leakproof bonnet, this chamber allows rapid access to valve trim for inspection and maintenance. Pressure boundary is sealed at the smallest diameter possible, to ensure maximum strength and low stress.

Thermal Isolation

Thermal isolation of the packing chamber increases packing life. The stainless steel packing chamber is a separate unit from the body, and therefore eliminates the need to remove or change packing after stress relieving.

STANDARD PACKING SYSTEM

*The proper packing procedure is:
Ordering Information*

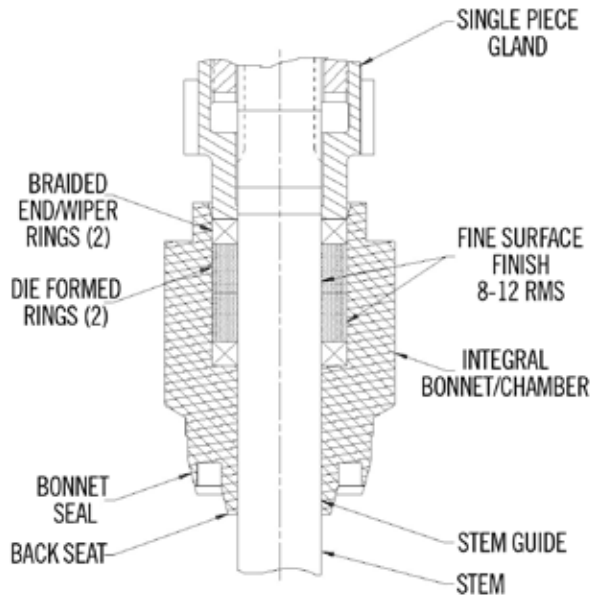

OPTIONAL LIVE LOADED PACKING SYSTEM

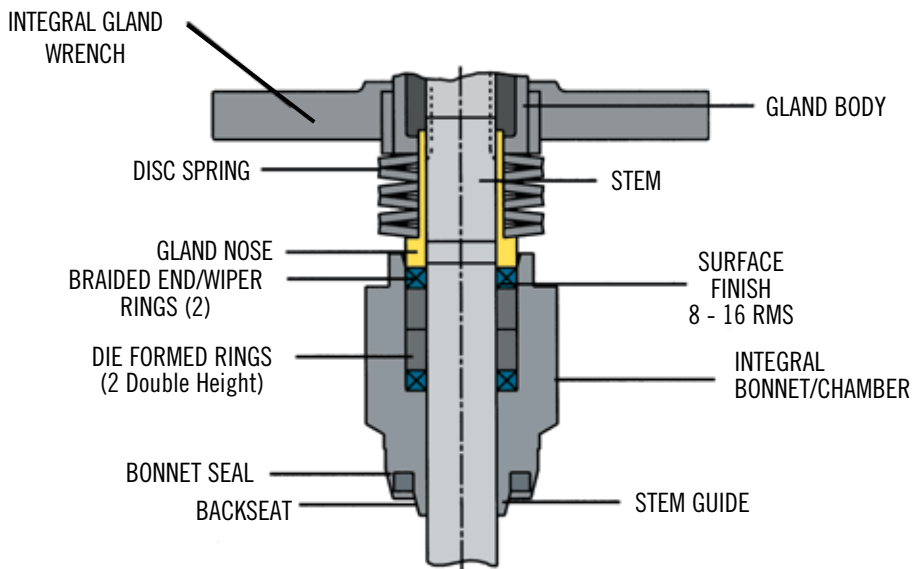

Optional Live Loaded Gland feature shown with the CLAMPSEAL® valve.

The Conval Story

In 1962, Mr. Chester Siver completed designs for a revolutionary line of high-pressure, forged steel valves. Hamilton Standard (now Hamilton Sunstrand), a division of United Technologies Corporation, was asked to use their then-new Electron Beam Welding technology for joining of parts into valves for subassemblies. Hamilton Standard became intrigued with the valve as an ideal application of the Electron Beam Welding technique, and negotiated a contract for the rights to manufacture and sell the valve. Mr. Siver served as manager of the valve project.



The first CLAMPSEAL® valves were introduced to the market by Hamilton Standard in 1964. However, in the mid-1960's, growing demand for the firm's popular aerospace products forced Hamilton Standard to make the decision to abandon its industrial products projects. The rights to the CLAMPSEAL valve reverted back to Mr. Siver. Since CLAMPSEAL valves were born in Connecticut, Mr. Siver founded "Conval" (short for Connecticut Valve) in 1967. Today, the valves are still manufactured in Connecticut, a state with a longstanding reputation for technological innovation and manufacturing excellence.

Founded in 1967, Conval has grown into a leader in valves for the world's most demanding applications. We have a global team of experts to help to meet your most challenging needs. We invite you to contact us today.

High-pressure, high-temperature ball, bellows, bonnetless, check, gate, globe, throttling, and urea service valves for the world's most demanding applications.



Thank you for your business!
ISO 9001 certified since 1992
PED certified since 2003
Nuclear N-stamp since 2006



Conval^{INC.}

World Headquarters: 96 Phoenix Avenue, Enfield, CT 06082 USA

Phone (860) 749-0761 Fax (860) 763-3557

e-mail: sales@Conval.com www.Conval.com

Conval's policy is one of continuous development and improvement. Every effort is made to produce up-to-date literature but this catalog should not be regarded as an infallible guide to current specifications and does not form part of any contract. Conval reserves the right to make product improvements and changes without prior notice.

Form PackingSystem2018E-KIT Printed in USA