



Clampseal® Throttling Valve Servicing Instructions



CLAMPSEAL® Throttling valves have unique features which enable them to be completely serviced in line.

The following service operations are possible:

- Seat/Orifice Replacement
 - Disc Refacing
 - Bonnet Seal Refacing
 - Replacement of Bonnet Chamber Assembly
 - Quick repacking by swapping bonnet chamber assemblies.
 - Repack old bonnet and return to stock.
-

TABLE OF CONTENTS

I. INSTALLATION	3
II. OPERATION	3
Operating Torques	5
Operating Gland Torques	7
III. PACKING GLAND ADJUSTMENTS	4
IV. MAINTENANCE	4
Routine Maintenance	4
Adding a Ring of Packing Under Pressure	4
V. REPAIR	5
Disassembly of Throttling Valves for Inspection and Repair	5-7
Repacking.....	8
Seat/Orifice Replacement.....	9
Disc	9
Bonnet Seat Refacing	9-10
Reassembly	10-11
VI. SUPPLEMENTARY INSTRUCTIONS	11
Storage	11
Handling.....	11
Torque Tools	11
VII. SERVICE TOOL CROSS REFERENCE	12
VIII. SIZE CODE CROSS REFERENCE	12

I. INSTALLATION

Perform installation welding in accordance with ASME Boiler and Pressure Vessel Code, Sec. I, Part PW, or ANSI B31.1 Para 127.

- A. **IMPORTANT DO NOT DISASSEMBLE VALVE.** Valve must be assembled and tightly closed during welding to protect seat from heat distortion and weld splatter.
- B. Allow 1/16” gap between bottom of socket and end of pipe (PW 41.5.7, or ANSI B31.1 Para 127.3.3).
- C. Preheat per Table 1.

II. OPERATION

All CLAMPSEAL® Throttling valve stems have right hand threads with clockwise rotation of the handle to close.

The CLAMPSEAL® Throttling valve has a backseat feature which, in the fully open position, isolates the packing from line pressure thereby increasing packing life. This is pressure assisted and requires only a light torque to effect a seal. See Table 2 for torque values.

Always check packing gland tightness before taking off backseat to prevent leakage.

**TABLE 1
PREHEAT AND POSTWELD HEAT TREAT REQUIREMENTS**

P-1 SA-105	P-5 SA-182 GR. F22	P-8 SA-182 GR. F316	P15E SA-182-F91
PREHEAT 50° F (A100.4.1) *	PREHEAT 400° F (A100.4.4) *	PREHEAT NONE REQUIRED (A100.4.7) *	PREHEAT 400° F (A100.4.12)
POST WELD HEAT TREAT NONE REQUIRED (PW-39)	POST WELD HEAT TREAT REQUIRED WHEN NOMINAL WALL THICKNESS EXCEEDS 5/8” (PW-39) LOCALIZED ONLY PER (PW-39-4-2)	POST WELD HEAT TREAT NONE REQUIRED (PW-39)	POST WELD HEAT TREAT REQUIRED (PW-39)

III. PACKING GLAND ADJUSTMENT

CLAMPSEAL® Throttling valves have a precision packing system with a single piece splined gland. Packing should be adjusted periodically to prevent leakage. See Table 3 for gland torques. Adjustment is especially important after hydro test or startup.

CLAMPSEAL® Throttling valves are furnished with an Integral Gland Wrench, Figure A. The I.G.W. provides for easy packing maintenance which helps extend packing life. Cycle valve several times while adjusting packing to improve packing seal.

FIGURE A

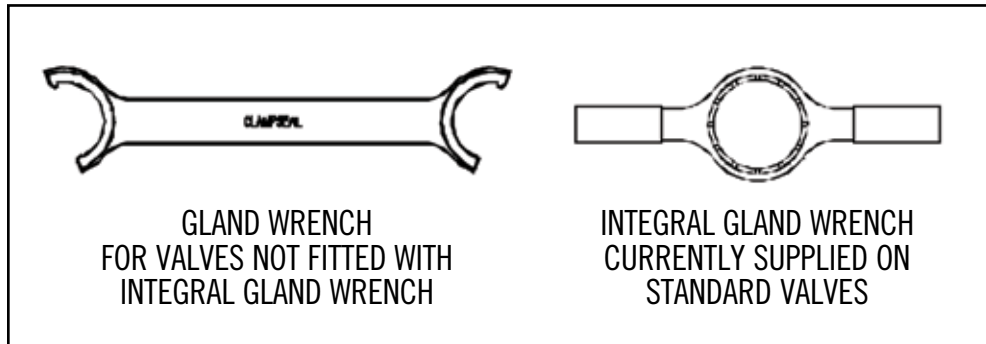

IV. MAINTENANCE

All components of the CLAMPSEAL® Throttling valve are shown and named in Figure B, page 6. CLAMPSEAL® Throttling valves have several distinctly different design features from other valves. These servicing instructions should be followed closely.

A. Routine Maintenance

Routine maintenance consists of a periodic tightening of the gland to prevent packing leakage. Graphite packing manufacturers recommend routine replacement of packing after 3 years of service. No other routine maintenance is required.

B. Adding a Ring of Packing Under Pressure

Packing will eventually wear to the point where tightening of the gland will not effect a seal. When this happens it is possible to add a packing ring under pressure as follows:

Note: This is only a temporary solution until the valve can be disassembled and repacked. When the valve is pressurized, the valve backseat provides pressure enhanced positive sealing. This feature does not provide a two valve protection which is specified in some safety standards. Proceed only as a last resort. Do not try to remove packing from a pressurized valve.

1. Open the valve fully and torque onto backseat. See Table 2 for torque. Over torquing will not enhance the seal and could cause damage.
2. Wait for leakage to stop while the fluid or gas trapped in the packing relieves itself.

CAUTION: IF LEAKAGE PERSISTS DO NOT PROCEED!

3. Remove handle to prevent accidental movement off of backseat.

4. Use gland wrench (Figure A.) to slowly screw the gland to full height on the yoke bushing, while checking for blow by.
5. Open graphitic yarn packing ring at split for insertion around the stem.
6. Slide ring into bonnet chamber and compress by tightening the gland. Loosen the gland to see if another ring will fit. If so, rotate second ring split one-quarter turn from first ring.
7. Tighten gland applying torques listed in Table 3.

TABLE 2
MAXIMUM OPERATING TORQUES (FT-LBS)

SIZE CODE	YOKE	SEATING	BACKSEAT	CLAMPBOLT
5E 5F 5G	150	60	6	15
7F 7G 7H 7J	250	100	9	25
8G 8H 8J 8K	350	230	12	25
10J	600	420	18	105
10K 10L 10M	600	500	25	105

V. REPAIR

A. Disassembly of Throttling Valves for Inspection and Repair

CAUTION: Before any attempt is made to disassemble the valve, verify that the valve is isolated from system pressure and secured against accidental pressurization. Follow standard tag out safety procedures before proceeding.

YOU MAY USE 1 OR 1A BELOW, BUT NOT BOTH.

1. Completely remove the clampbolt from the yoke and screw it into the opposite (threaded) side of the clampbolt lug. Place a metal flat (like a fender washer) into the yoke split to stop the clampbolt. Tighten clampbolt, using it as a jacking screw, until the yoke split expands by 1/16" to 1/4" in large valve (this is to relieve yoke thread friction).
- 1A. Completely remove the clampbolt from the yoke and keep the clampbolt for reassembly. Drive a small wedge (similar to a wood chisel) straight down into the split in the clampbolt lug until the yoke split expands by 1/16" to 1/4" on large valves. **CAUTION: When using method 1A, always drive the wedge straight down, never drive the wedge toward the body threads or thread damage could occur.**
2. Unscrew the yoke, using a Conval Yoke Wrench. Remove the yoke assembly carefully so that the stem and disc do not scratch the bonnet sealing surface. If the bonnet becomes stuck in the body, proceed with steps 3-5 and use a small wedge under the bonnet flange.

NOTE: VALVE WITH SIZE CODES 8 AND 10 HAVE HANDLE & ADAPTOR (IMPACTOR HANDLE)

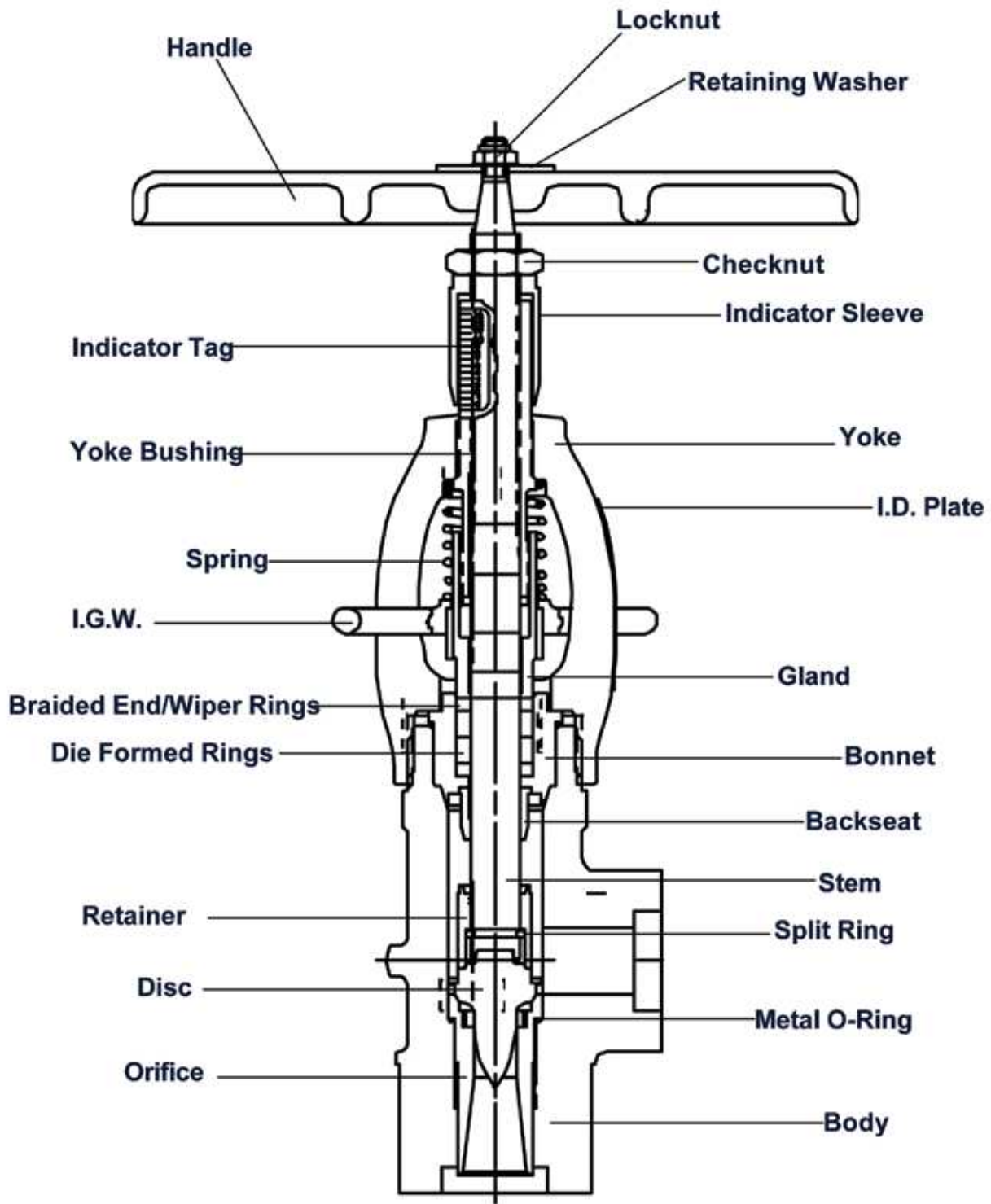

FIGURE B

TABLE 3
SEI - 26 OPERATING GLAND TORQUES (FT-LBS)

SIZE CODE	ASME/ANSI PRESSURE CLASS									
	600	900	1195	1500	2155	2500	3045	3500	4095	4500
5E	8	8	8	8	9	10	12	-	-	-
5F	8	8	8	8	9	-	-	-	-	-
5G	8	8	8	-	-	-	-	-	-	-
7F	15	15	15	15	16	19	23	26	30	-
7G	15	15	15	15	16	19	23	-	-	-
7H	15	15	15	15	16	-	-	-	-	-
7J	15	15	15	-	-	-	-	-	-	-
8G	18	18	18	18	20	23	28	32	37	-
8H	18	18	18	18	20	23	28	-	-	-
8J	18	18	18	18	20	-	-	-	-	-
8K	18	18	18	-	-	-	-	-	-	-
10J	37	37	37	37	40	40	56	64	75	-
10K	47	47	47	47	50	50	71	-	-	-
10L	47	47	47	47	50	-	-	-	-	-
10M	47	47	47	-	-	-	-	-	-	-

3. Remove lock nut, washer, and valve handle.
4. Remove the check nut. After removing the check nut thread off the indicator sleeve.
5. Removal of the stem from the yoke assembly requires threading the stem down through the yoke bushing. To make removal easier, it is helpful to clean the stem threads thoroughly with a wire brush and solvent. Some filing may also be required to clean the threads at the handle flats.
6. Remove timing shims (if supplied) from bonnet. Shims are provided in some valves to maintain proper yoke orientation. Keep the original shim set with the valve for reassembly.
7. To remove bonnet, invert stem and press bonnet down over stem.
8. Inspect the condition of the following sealing surfaces for damage:
 - * **Body:** bonnet seal
 - * **Stem:** disc sealing surface and needle, packing sealing surface, backseat lip of retainer
 - * **Bonnet:** backseat nose, body seal, packing chamber surface
 - * **Venturi:** seat and venturi

B. REPACKING

1. Remove old packing using a soft dowel (wood, plastic or brass). Put bonnet on table upside down and press rings out from the bottom. It's helpful to soak the bonnet and packing in solvent to loosen packing before removal.

WARNING: Do not use a standard packing puller. It will cause scoring of the bonnet chamber and create a leak path.

FIGURE C

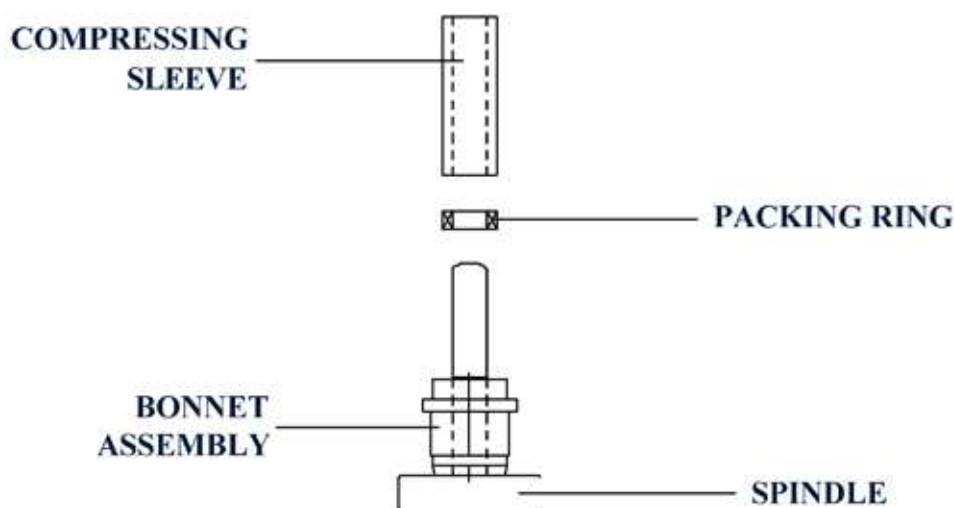

2. Clean bonnet chamber in clean solvent to remove contaminants which will contribute to stem pitting. Place the bonnet assembly over the spindle of the Conval repacking tool, adding rings individually and manually depress them into the chamber with the compressing sleeve. No preloading is required. The order of assembly is as shown in Figure C.

NOTE: Use only dieformed graphitic seal rings and woven graphitic wiper rings for best packing performance. See below for correct size.

REPACKING TOOL	SIZE CODE	PACKING RINGS		WIPER RINGS	
		OD X ID X HT	QTY	OD X ID X HT	QTY
T5-RP-1	5E 5F 5G	1 X 5/8 X 3/8	2	1 X 5/8 X 3/16	2
T7-RP-1	7F 7G 7H 7J	1 1/4 X 3/4 X 1/2	2	1 1/4 X 3/4 X 1/4	2
T8-RP-1	8G 8H 8J 8K	1 3/8 X 7/8 X 1/2	2	1 3/8 X 7/8 X 1/4	2
T9-RP-1	10J	1 3/4 X 1 1/8 X 3/8	3	1 3/4 X 1 1/8 X 5/16	2
T10-RP-1	10K 10L 10M	1 7/8 X 1 1/4 X 5/8	2	1 7/8 X 1 1/4 X 5/16	2

C. SEAT/ ORIFICE REPLACEMENT

1. Disassemble valve (Section V., Part A.)
2. Insert hex bar or Conval orifice replacement tool into seat/orifice insert.(See Table 4 for hex size) Attach wrench and unscrew (counter clockwise).
3. Remove old seat/orifice insert from the valve.
4. Remove old metal o-ring from the valve.
5. Inspect o-ring seating area and threads to make sure they are clean.

D. DISC

If the disc sealing surface or needle is damaged the stem assembly will need to be repaired or replaced. To repair the disc chuck the retainer portion of the stem assembly in a lathe and center to within .001". Use a single point carbide tool (Kennametal Grade K68 or equal) with a fine feed and cutting speed of 30 - 50 S.F.P.M. Machine the minimum amount of metal necessary to clean the surface to minimum $29^{\circ} \pm 10'$.

FIGURE D

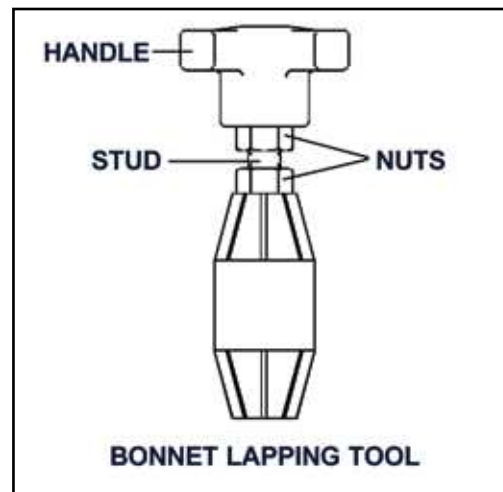

NOTE: SEE BACK PAGE FOR BONNET LAPPING TOOL PART NUMBERS.

E. BONNET SEAT REFACING

1. Assemble Bonnet Lapping Tool as shown in Figure D.
2. Apply a small amount of Lapping Compound to the seating surface of the Bonnet Lapping Tool. Use compound 120 (coarse) for rough lapping, 280 (fine) for final lapping.
3. Apply slight downward pressure on the Bonnet Lapping Tool. Lap back and forth until a smooth finish on the bonnet lip is achieved.
4. Clean parts thoroughly with solvent and a clean rag.

F. REASSEMBLY

1. Clean all parts thoroughly with cleaning solvent.
2. Coat body/yoke threads and venturi threads with a nickel anti-seize lubricant.
3. Assemble the components in the following order:
 - a. Use repacking tool sleeve to hold packing inside of the bonnet chamber as bonnet is slid onto stem assembly.
 - b. Screw packing gland to its highest point on the yoke bushing.
 - c. Replace timing shims (if shims were provided originally) onto bonnet chamber and screw stem assembly into yoke to mid-travel position. Keep timing shims flat on bonnet ledge.

TABLE 4

SEAT	VENTURI HEX	ORIFICE
E	7/16	5/16
F	9/16	3/8
G	7/8	7/16
H	1	9/16
J	1 1/8	3/4
K	1 5/16	7/8
L	1 1/2	1
M	2 1/4	1 1/2

- d. Lubricate o-ring shoulder on seat/orifice insert and slide on a new metal o-ring. Lubricant should be low temperature and is used to hold o-ring in place during assembly.
- e. Screw in seat/orifice insert (clockwise), with new metal o-ring attached, using hex bar or Conval orifice replacement tool (see Table 4 for hex size). Tighten firmly to torques given in Table 5 below:

TABLE 5

Valve Size Code	Orifice Installation torque (ft-lbs)*
5E/5F	60
7G	60
8H	100
10K	300

* The installation torque is approximately 1.5 times the maximum seating torque for the given valve sizes.

1. Replace the indicator sleeve, with the valve in the closed position, by screwing it back on the stem, making sure that the bottom of the indicator sleeve is resting at "0" on the indicator tag. Then screw on the check nut. The check nut should be snug, to lock the indicator sleeve in place.
- f. Use clampbolt to spread yoke as described in section V.A. 1, Page 4. Place yoke assembly into body. Avoid contact between disc and body/bonnet seal surface as the yoke assembly is placed into body.
 - g. Screw yoke onto body. Insure that stem is in mid travel and gland is at top of yoke bushing. Apply torque as specified in Table 2. **DO NOT OVER TORQUE!**
 - h. If yoke alignment must be changed add .030" thick shims for each 90° of desired rotation.
 - i. Return clampbolt to normal position and tighten per Table 2.
 - j. Place handle and fasteners onto stem and tighten.
 - k. Cycle valve several times to seat packing and readjust packing gland. Tighten packing gland per Table 3.

VI. SUPPLEMENTARY INSTRUCTIONS

A. STORAGE

All valves are treated with rust-preventative, capped, and sealed in polyethylene bags to repel moisture. Valves should be stored in a weatherproof enclosure on pallets or shelving to isolate valve from moisture.

B. HANDLING

CLAMPSEAL® valves are extremely rugged and damaging them during handling is difficult. However, some care must be taken in handling. Do not drop them. Use yoke arm or body to lift valve. Do not lift by valve handle.

C. TORQUE TOOLS

The following torque tools are available:

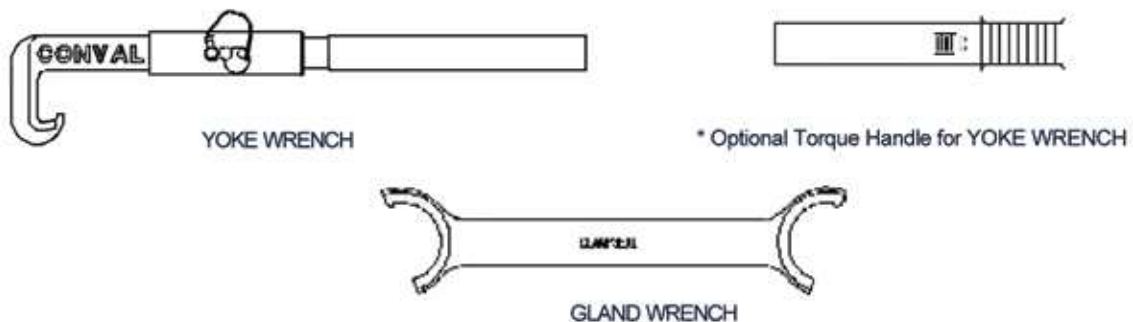

VII. SERVICE TOOL CROSS REFERENCE

SIZE CODE	LAPPING TOOLS BONNET	REPACK TOOL	YOKE WRENCH*	TORQUE WRENCH
5E	T5EF-LB-1	T5-RP-1	T3/6-YW-1	T3/6-GW
5F	T5EF-LB-1	T5-RP-1	T3/6-YW-1	T3/6-GW
5G	T5G-LB-1	T5-RP-1	T3/6-YW-1	T3/6-GW
7G	T7F-LB-1	T7-RP-1	T7/10-YW-1	T7/8-GW
7G	T7GH-LB-1	T7-RP-1	T7/10-YW-1	T7/8-GW
7H	T7GH-LB-1	T7-RP-1	T7/10-YW-1	T7/8-GW
7J	T7J-LB-1	T7-RP-1	T7/10-YW-1	T7/8-GW
8G	T8G-LB-1	T8-RP-1	T7/10-YW-1	T7/8-GW
8H	T8HJ-LB-1	T8-RP-1	T7/10-YW-1	T7/8-GW
8J	T8HJ-LB-1	T8-RP-1	T7/10-YW-1	T7/8-GW
8K	T8K-LB-1	T8-RP-1	T7/10-YW-1	T7/8-GW
10J	T10J-LB-1	T9-RP-1	T7/10-YW-1	T9-GW
10K	T10KL-LB-1	T10-RP-1	T7/10-YW-1	T10-GW
10L	T10KL-LB-1	T10-RP-1	T7/10-YW-1	T10-GW
10M	T10M-LB-1	T10-RP-1	T7/10-YW-1	T10-GW

*Optional snap-on torque handle available.

VIII. SIZE CODE CROSS REFERENCE

All CLAMPSEAL® valves are distinguished by a size code which defines tool and part interchangeability. The size code is stamped on all valve bodies just below the threads and directly above the round raised pad where the steel heat code is stamped. Size codes consist of a number followed by a letter. The number refers to the body forging size and the letter refers to the seat size. This table lists Conval's standard size codes for given configurations. Reference size code when ordering parts or tools.

Always confirm the size code by inspecting the valve.

PRESSURE CLASS	0.75	1.00	1.25	1.50	2.00	2.50	3.00	4.00
900	5G	5G	5G	7J	7J, 8K	8K	10M	10M
1500	5F	5F, 7H	7H, 8J	7H, 8J	8J	10L	10L	10L
2500	5E	5E, 7G	7G, 8H	7G, 8H	8H, 10K	10K	10K	-
3500	-	7F	7F, 8G	7F, 8G	8G, 10J	10J	10J	-



World Headquarters: 96 Phoenix Avenue, Enfield, CT 06082 USA

Phone (860) 749-0761 Fax (860) 763-3557

e-mail: sales@Conval.com www.Conval.com

Conval's policy is one of continuous development and improvement. Every effort is made to produce up-to-date literature but this catalog should not be regarded as an infallible guide to current specifications and does not form part of any contract. Conval reserves the right to make product improvements and changes without prior notice.