



World Class Clampseal® Piston Check Valves

- *Exclusive Pressure Seal Bonnet*
- *Easy In-line Maintenance*
- *Lightest Weight in Class*
- *Highest Strength to Meet Code*



Conval Clampseal® Check Valves are designed for demanding high-pressure applications where light weight and compact size are required.



STANDARD SIZES

1/2" through 3"
Y, T, angle pattern
Stop Check Optional
SW, BW, FNPT (to 1"). Grayloc or Flanged

PRESSURE RATING

ASME 900 through 3500

STANDARD MATERIALS

A105, F22, F316, 316L
Monel™ 400, Inconel™ 600, optional

DESIGN FEATURES

Clampseal Check Valves feature the exclusive pressure seal bonnet which permits ready access for maintenance, while ensuring a positive pressure-actuated body to bonnet seal under all operating conditions.

The valve is comprised of five assemblies, with the piston and spring being the only moving parts. The piston utilizes two guide rings, and the spring is Inconel X for smooth operation in any position at temperatures up to 1000°F.

The reliability of the Clampseal Check Valve is enhanced by use of the electron beam process for welding the cast stellite seat into the body. By using the inline maintenance tools available, long valve life can be assured.

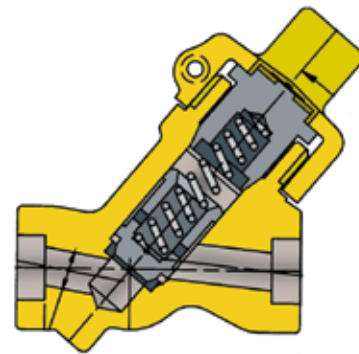

ISO 9001 certified since 1992

PED certified since 2003



Conval INC.

World Headquarters: 96 Phoenix Avenue, Enfield, CT 06082 USA

Phone (860) 749-0761 Fax (860) 763-3557

e-mail: sales@Conval.com www.Conval.com

Conval's policy is one of continuous development and improvement. Every effort is made to produce up-to-date literature but this catalog should not be regarded as an infallible guide to current specifications and does not form part of any contract. Conval reserves the right to make product improvements and changes without prior notice.