

Conval INC.

World Class Steam Whisperjets

- *High Pressure Drop*
- *Virtually No Part Erosion*
- *Flexible Number of Stages*
- *Lower Noise*
- *Save Component Wear*



Conval Whisperjets are designed to reduce steam pressure without causing component wear.



STANDARD SIZES

1/2" through 4"
SW, BW Ends
Y, Angle and T-Pattern

PRESSURE RATING

Through ANSI Class 4500

STANDARD MATERIALS

Carbon Steel A105
Low Alloy SA 182-F22

STANDARD ACCESSORIES

Actuators - Electric, Pneumatic, and Manual



DESIGN FEATURES

Long Device Life

With the Whisperjet, steam impinges itself to reduce pressure as it flows through a series of multi-pressure reduction stages. Steam does not rely solely on a tortuous path like most pressure letdown devices; thus, there is virtually no part erosion, which you would commonly see in orifice plates or other pressure letdown devices.

Longer System Life

When Whisperjets are used in conjunction with a valve or other system components, the seat life of the valve is substantially increased. When used before a condenser or flash tank, baffle and tank wear are greatly reduced.

Reliable

Whisperjets have been installed in power plant applications around the world for over 25 years. They are proven to be rugged and reliable in high-pressure environments.

Reduced Noise

Each section has 4-6 orifices around its perimeter. The orifices discharge inwardly, which reduces the steam pressure without causing component wear. Pressure is reduced in stages, which prevents a critical pressure drop. Each stage is progressively larger, allowing the steam to expand. The orifices are sized to keep the flow of steam below critical velocity. This gives the advantage of reduced noise.

Economical

Due to their simple, practical design and operation, Whisperjets are low-cost solutions to steam erosion problems.

Flexible

The number of Whisperjet stages may be varied for almost any flow requirement. Our engineering department will work with you to custom-specify Whisperjet to meet your needs.

SPECIFICATIONS

(5) Static Pressure-psi

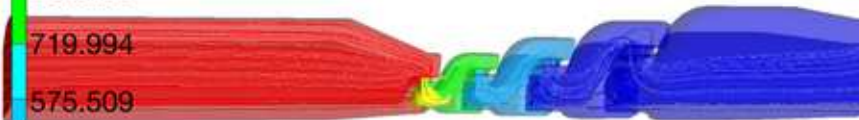
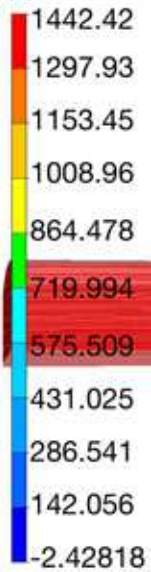

This Finite Element Analysis graph demonstrates the pressure drop through a four-stage Whisperjet. Upon request, Conval can create a similar graph for your custom application.

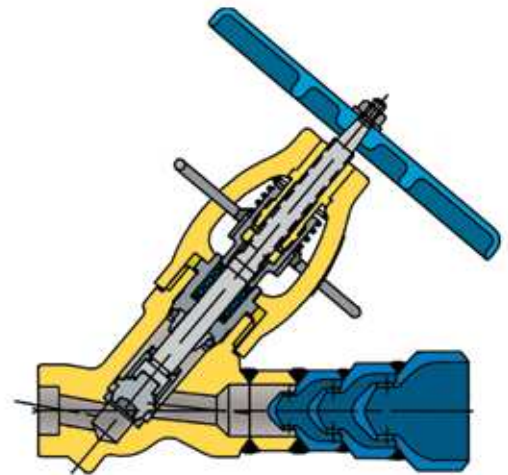
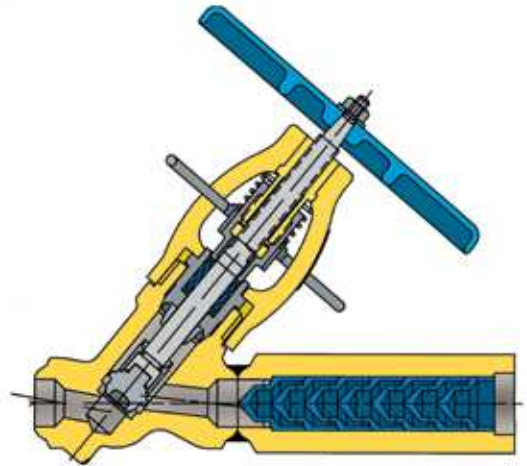

Gas

Water



Typical Specification A

Steam entering the condenser

- Temperature: 1005°F
- Pressure entering valve: 2660 psi
- Pressure exiting Whisperjet into condenser: 50 psi
- Inlet pipe size: 1/2"
- Outlet pipe size: 3"
- Solution: 7-stage Whisperjet

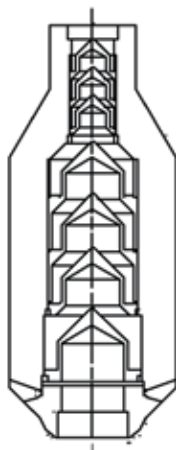

Typical Specification B

Steam turbine after seat drain

- Temperature: 1005°F
- Pressure entering valve: 3675 psi
- Pressure exiting Whisperjet (when valve is full open): 2575 psi
- Inlet pipe size: 1-1/2"
- Outlet pipe size: 1-1/2"
- Solution: Conval Throttling Valve with 1/2" orifice and 3-stage Whisperjet

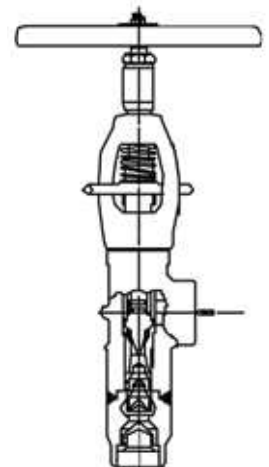

For valve sizing and specifications, please consult your local representative or contact us directly.

The Conval Story

In 1962, Mr. Chester Siver completed designs for a revolutionary line of high-pressure, forged steel valves. Hamilton Standard (now Hamilton Sunstrand), a division of United Technologies Corporation, was asked to use their then-new Electron Beam Welding technology for joining of parts into valves for subassemblies. Hamilton Standard became intrigued with the valve as an ideal application of the Electron Beam Welding technique, and negotiated a contract for the rights to manufacture and sell the valve. Mr. Siver served as manager of the valve project.



The first CLAMPSEAL® valves were introduced to the market by Hamilton Standard in 1964. However, in the mid-1960's, growing demand for the firm's popular aerospace products forced Hamilton Standard to make the decision to abandon its industrial products projects. The rights to the CLAMPSEAL valve reverted back to Mr. Siver. Since CLAMPSEAL valves were born in Connecticut, Mr. Siver founded "Conval" (short for Connecticut Valve) in 1967. Today, the valves are still manufactured in Connecticut, a state with a longstanding reputation for technological innovation and manufacturing excellence.

Founded in 1967, Conval has grown into a leader in valves for the world's most demanding applications. We have a global team of experts to help to meet your most challenging needs. We invite you to contact us today.

High-pressure, high-temperature ball, bellows, bonnetless, check, gate, globe, throttling, and urea service valves for the world's most demanding applications.



*Thank you for your business!
ISO 9001 certified since 1992
PED certified since 2003
Nuclear N-stamp since 2006*



MADE IN

U. S. A

Conval INC.

World Headquarters: 96 Phoenix Avenue, Enfield, CT 06082 USA

Phone (860) 749-0761 Fax (860) 763-3557

e-mail: sales@Conval.com www.Conval.com

Conval's policy is one of continuous development and improvement. Every effort is made to produce up-to-date literature but this catalog should not be regarded as an infallible guide to current specifications and does not form part of any contract. Conval reserves the right to make product improvements and changes without prior notice.